

# EL1

---

## EARTH LEAKAGE PROTECTION RELAY

### TECHNICAL REFERENCE GUIDE



VOLUME 1.0

FIGURE 1 EL1 EARTH LEAKAGE PROTECTION RELAY

---

# Contents

## *EL1 1*

<i>Contents</i>	2
<i>List of figures</i>	4
<b>1. Introduction</b>	<b>5</b>
<b>About this manual</b>	<b>5</b>
<b>About the EL1</b>	<b>5</b>
<b>EL1 HMI (human machine interface)</b>	<b>7</b>
<b>Warranty</b>	<b>9</b>
<b>2. Safety information</b>	<b>9</b>
<b>3. Supply Voltage</b>	<b>9</b>
<b>4. Input 1 (IP1)</b>	<b>10</b>
<b>5. Relay outputs</b>	<b>10</b>
<b>6. Earth leakage test</b>	<b>11</b>
<b>7. Alarm</b>	<b>12</b>
<b>8. Trip</b>	<b>12</b>
<b>9. Menu</b>	<b>12</b>
<b>About the Menu</b>	<b>12</b>
<b>How to change the settings</b>	<b>12</b>
<b>List of Menu Settings</b>	<b>13</b>
Mode	14
Earth Fault level STANDBY	14
Trip delay STANDBY	14
Startup time	14
Earth Fault level START	14
Trip delay START	14
Earth Fault level RUN	14
Trip delay RUN	14
Earth Fault test level	15
Sample time	15
K2 Latch	15
External Reset	16
<b>10. Screen</b>	<b>16</b>
<b>11. Led</b>	<b>17</b>

<b>12. RTOS (Real time operating system)</b>	<b>18</b>
STATE MACHINE	18
<b>13. About</b>	<b>19</b>
<b>14. Electrical specifications</b>	<b>19</b>
<b>15. Terms and conditions</b>	<b>20</b>
Product Agreement	20

# List of figures

Figure 1 EL1 Earth Leakage protection relay.....	1
Figure 2 Human machine interface.....	7
Figure 3 Infra red remote control.....	8
Figure 4 Typical auto earth test connection.....	11
Figure 5 Lcd.....	16
Figure 6 Led indication.....	17

# 1. Introduction

## ***About this manual***

This manual was prepared to aid the engineer in the configuration, setup and implementation of the EL1 in electrical systems with easy to understand terms and procedures.

## ***About the EL1***

The EL1 Earth Leakage protection relay is the most advanced Earth Leakage protection on the market to date. The EL1 measures true RMS (harmonic immune) sensitive earth leakage accurately from 25mA to 10.0A. Auto earth leakage test, alarm and trip outputs are available with internal power backup to keep led indicators active for up to 3 hours after at trip (power down). Non volatile trip state will remain active even after long power down. Three different trip levels with trip delays are available for the three states (STANDBY, STARTUP and RUN).

## The EL1 offers:

- One true RMS voltage channel (Supply voltage)
- One true RMS Current channel (Core balance)
- One 115/250Vac input (Contactor ON / External Reset)
- Two voltage free relay contacts (Auto test/Alarm and Trip)
- Sensitive earth leakage protection true RMS
- Remote controlled Infra red port
- Internal power backup after trip to indicate last state
- Three different trip levels
- Three different trip delays
- External reset

The EL1 is locally manufactured to international standards utilizing the best components available. We offer 24/7 toll free technical support, backup service and training.

### ***EL1 HMI (human machine interface)***

The EL1 operates as a user friendly device with real time data available to the operator. All the data is available on the 8x2 LCD display and all parameters are adjustable via handheld infra red remote control.



FIGURE 2 HUMAN MACHINE INTERFACE

---

The easy to use handheld infra red remote control is used to navigate through the menu and adjust any of the settings.

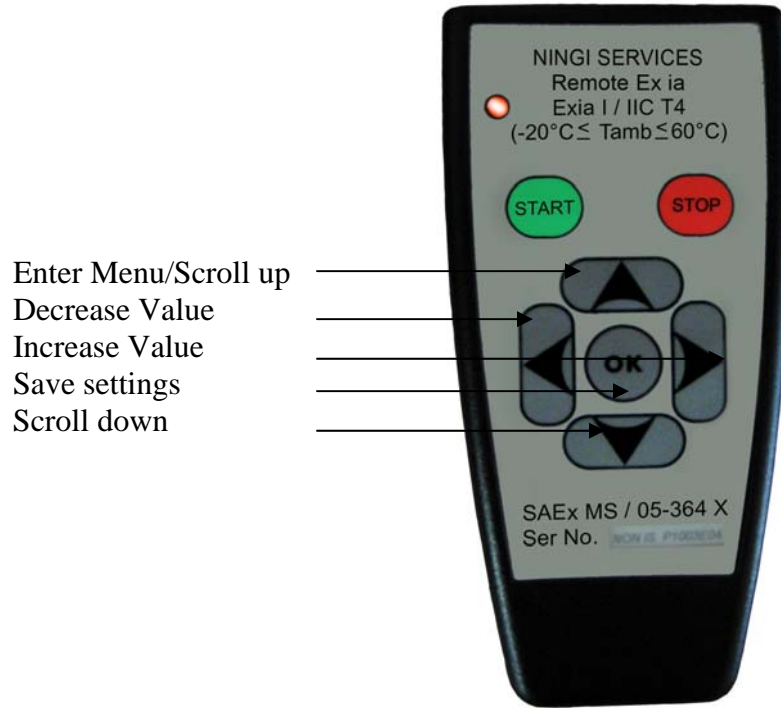

FIGURE 3 INFRA RED REMOTE CONTROL

### ***Warranty***

The EL1 carries a one year limited warranty on all parts and labor.

## **2. Safety information**

- ❖ Dangerous voltages can occur on the connectors, even if the auxiliary voltage has been disconnected.
- ❖ Only a certified electrician is allowed to carry out the electrical installation.
- ❖ Breaking the seal on the fixing screws of the device will result in loss of warranty.
- ❖ Electrical safety regulations must always be followed.

## **3. Supply Voltage**

The operation voltage is 85 ~ 265 Vac.

## 4. Input 1 (IP1)

Input 1 can operate in one of the following modes:

1. When the menu setting “**External Reset**” is set to OFF, the input (**IP1**) is used to change the EL1 state from STANDBY to STARTUP and then RUN ([see RTOS](#)). De-energize the input (**IP1**) change state from STARTUP or RUN back to STANDBY.
2. When “**External Reset**” is set to ON the input (**IP1**) is used as an external reset to reset the EL1 after trip.

## 5. Relay outputs

Two voltage free relay change over contacts (8A @ 240Vac) are available on the EL1. K2 is used for trip. K1 is used in one of the following modes:

1. When the menu setting “**E/F Test**” (Earth Fault test level) is set to OFF relay K1 is used for alarm. The alarm relay become active immediately when the earth fault level exceed the setting. The alarm relay de-energize when the trip relay energize.
2. When the menu setting “**E/F Test**” (Earth Fault test level) is set to any level relay K1 is used for auto earth leakage test. [See Earth Leakage Test](#)

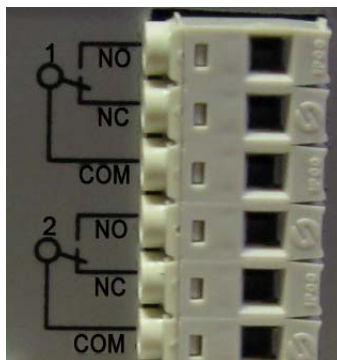

## 6. Earth leakage test

Earth Fault test level - K1 is used for auto earth leakage test.

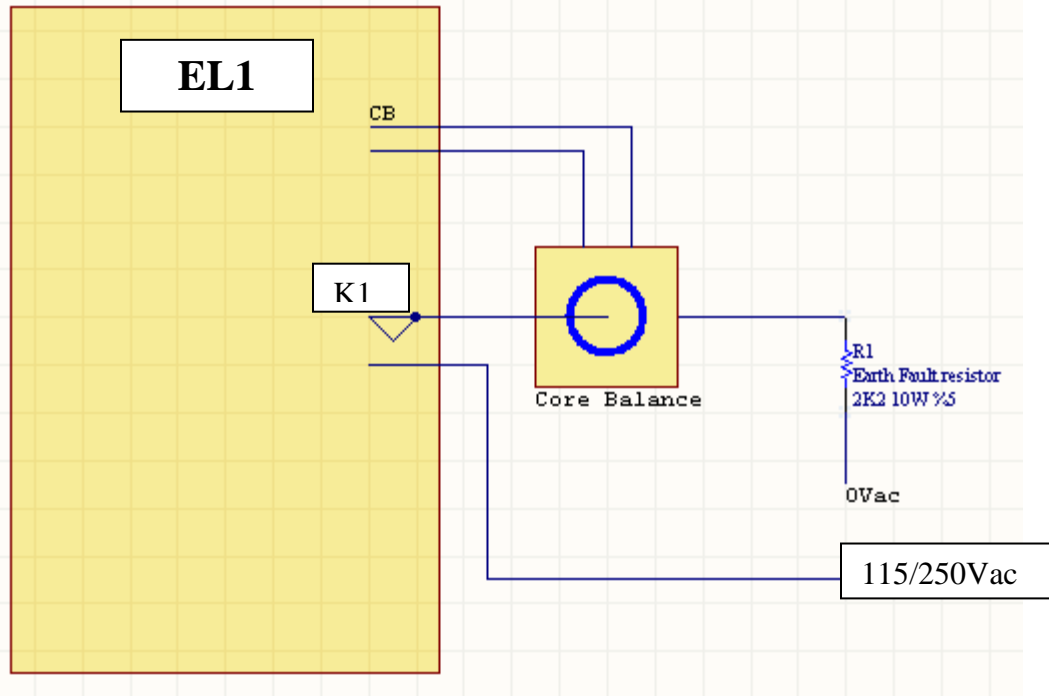

FIGURE 4 TYPICAL AUTO EARTH TEST CONNECTION

Example: On STARTUP the relay is energized and an earth fault is momentary induced into the system. If the induced earth fault is detected the Earth Leakage continue with the operation. If no induced earth fault is detected the LCD will display **E/F FAIL** and the EL1 will trip.

## 7. Alarm

The alarm relay energize instantaneous when the earth fault reading exceed the set level (Menu setting E/F test = OFF). The Alarm relay K1 will reset when Trip relay K2 energize.

*Example: To prevent the contactor to open under load or a heavy earth fault condition, the alarm relay K1 can be used to trip the circuit breaker shunt prior to the trip relay K2 which is connected to the contactor.*

## 8. Trip





The EL1 change state to trip when the earth fault reading exceeds the set level. See [trip delay](#) for STANDBY, STARTUP and RUN trip times. Press the reset button or energize IP1 (when [external reset](#) = ON) to reset the EL1 when tripped.



## 9. Menu

### **About the Menu**

The EL1 menu contains all the settings for the 3 trip levels and 3 trip delays (STANDBY, STARTUP and RUN). Various other settings are also available in the MENU. The menu settings are located in a non volatile memory. The EL1 menu settings can only be changed by infra red remote control.

### **How to change the settings**

Press the  button on the infra red remote control to enter the menu. Then press  or  to scroll up or down through the menu.  Or  will decrease or increase the value for that specific setting.

Press the  button to exit the menu. To save the settings press the  button again within 10 seconds.

### **List of Menu Settings**

<b>REGISTER</b>	<b>SETTING</b>	<b>LCD / Screen</b>	<b>MIN</b>	<b>MAX</b>	<b>DEFAULT</b>	<b>UNIT</b>
40001	Mode	Mode	0	5000	0	
40002	Earth Fault level STANDBY	E/FStdby	0	6500	500	mA
40003	Trip delay STANDBY	DlyStdby	0	999.9	0.2	Sec
40004	Startup time	Start up	0	999.9	5.0	Sec
40005	Earth Fault level START	E/FStart	0	6500	500	mA
40006	Trip delay START	Dly Strt	0	999.9	0.1	Sec
40007	Earth Fault level RUN	E/F Run	0	6500	250	mA
40008	Trip delay RUN	Dly Run	0	999.9	0.1	Sec
40009	Earth Fault test level	E/F Test	0	9999	100	mA
40010	Sample time	Cycles	20	5000	100	ms
40011	K1 Latch	K1 Latch	Off	ON	ON	
40012	External Reset	ExtReset	Off	ON	OFF	

## Mode

This setting is used for special functions. .

*The following modes will:*

**Mode 255** Default the menu settings to factory values

## Earth Fault level STANDBY

This setting is the earth fault trip level (25mA to 10 000mA) when the EL1 is in STANDBY. If the earth fault level exceed the setting the alarm relay energize. See [Trip delay STANDBY](#) for trip time.

## Trip delay STANDBY

This is the delay time before trip in the event of an earth leakage fault. See [Electrical specification](#) for instantaneous trip time.

## Startup time

This function changes the EL1 state from STARTUP to RUN after delay setting “STARTUP”

## Earth Fault level START

This setting is the earth fault trip level (25mA to 10 000mA) when the EL1 is in STARTUP. If the earth fault level exceed the setting the alarm relay energize. See [Trip delay START](#) for trip time.

## Trip delay START

This is the delay time before trip in the event of an earth leakage fault. See [Electrical specification](#) for instantaneous trip time.

## Earth Fault level RUN

This setting is the earth fault trip level (25mA to 10 000mA) when the EL1 is in STARTUP. If the earth fault level exceed the setting the alarm relay energize. See [Trip delay RUN](#) for trip time.

## Trip delay RUN

This is the delay time before trip in the event of an earth leakage fault. See [Electrical specification](#) for instantaneous trip time.

## Earth Fault test level

This setting is the required induced earth fault level for auto earth leakage test.

Calculate  $I_{test}$  setting with the following formula.

$$I_{test} = V_{aux} / R_{test}.$$

Where:

$I_{test}$  = induced earth fault

$V_{aux}$  = control circuit voltage

$R_{test}$  = earth leakage test resistor value

Example:

$$V_{aux} = 240\text{Vac}$$

$$R_{test} = 2200 \text{ ohm}$$

$$I_{test} = 240 / 2200$$

$$= \underline{109 \text{ mA}}$$

**Set Earth Fault test level below 109mA. Set the level to 100mA.**

Calculate the test resistor watt rating:

$$P_{resistor} = I_{test} * I_{test} * R_{test}$$

$$P_{resistor} = 0.109 * 0.109 * 2200$$

$$= \underline{26\text{Watt}}$$

## Sample time

True RMS earth fault reading is calculated by sampling the core balance. The minimum sampling time for a 50HZ system is 20ms (One cycle). Adjust the sampling time to 20ms to ensure very fast trip times. Increase the sampling time for better accuracy and immunity to noise. Set to 100ms for sampling over 5 cycles, this is the default setting.

## K2 Latch

K2 will latch on trip when set to LATCH. For momentary relay operation after trip set to the required operating time.

## External Reset

External reset is set to OFF.

1. When the EL1 is in STANDBY, energizing IP1 will change the EL1 state from STANDBY to STARTUP.

External reset is set to ON.

1. When the EL1 is in tripped state, energizing IP1 reset the EL1.

# 10. Screen

The LCD screen display the following information: The top line of the LCD displays the status of the EL1. The bottom line of the LCD displays the earth fault reading.

LCD TOP LINE	DESCRIPTION
STANDBY	STATE - STANDBY
STARTUP	STATE - STARUP
RUN	STATE - RUN
LCD BOTTOM LINE	DESCRIPTION
0 mA	Earth leakage reading in mA

FIGURE 5 LCD

# 11. Led

LED GREEN – System OK

LED TRIP – EL1 tipped

K1 – Relay 1 energized (ALARM/AUTO TEST)

K2 – Relay 2 energized (TRIP)



FIGURE 6 LED INDICATION

---

## 12. RTOS (Real time operating system)

The EL will always be in one of the following states.

- STANDBY
- STARTUP
- RUN
- TRIP

Different levels of protection can be set for each state. Instantaneous trip or definite time trip is available for each state. This enables the EL1 to give an alarm or trip at different earth fault levels at each state. If IP1 energized (contactor) the EL1 change state from **STANDBY** to **STARTUP**. If the **STARTUP** time exceed the setting “**STARTUP**” the EL1 change the state from **STARTUP** to **RUN**. When IP1 de-energize the EL1 change the state from **STARTUP** or **RUN** back to **STANDBY**.

### STATE MACHINE

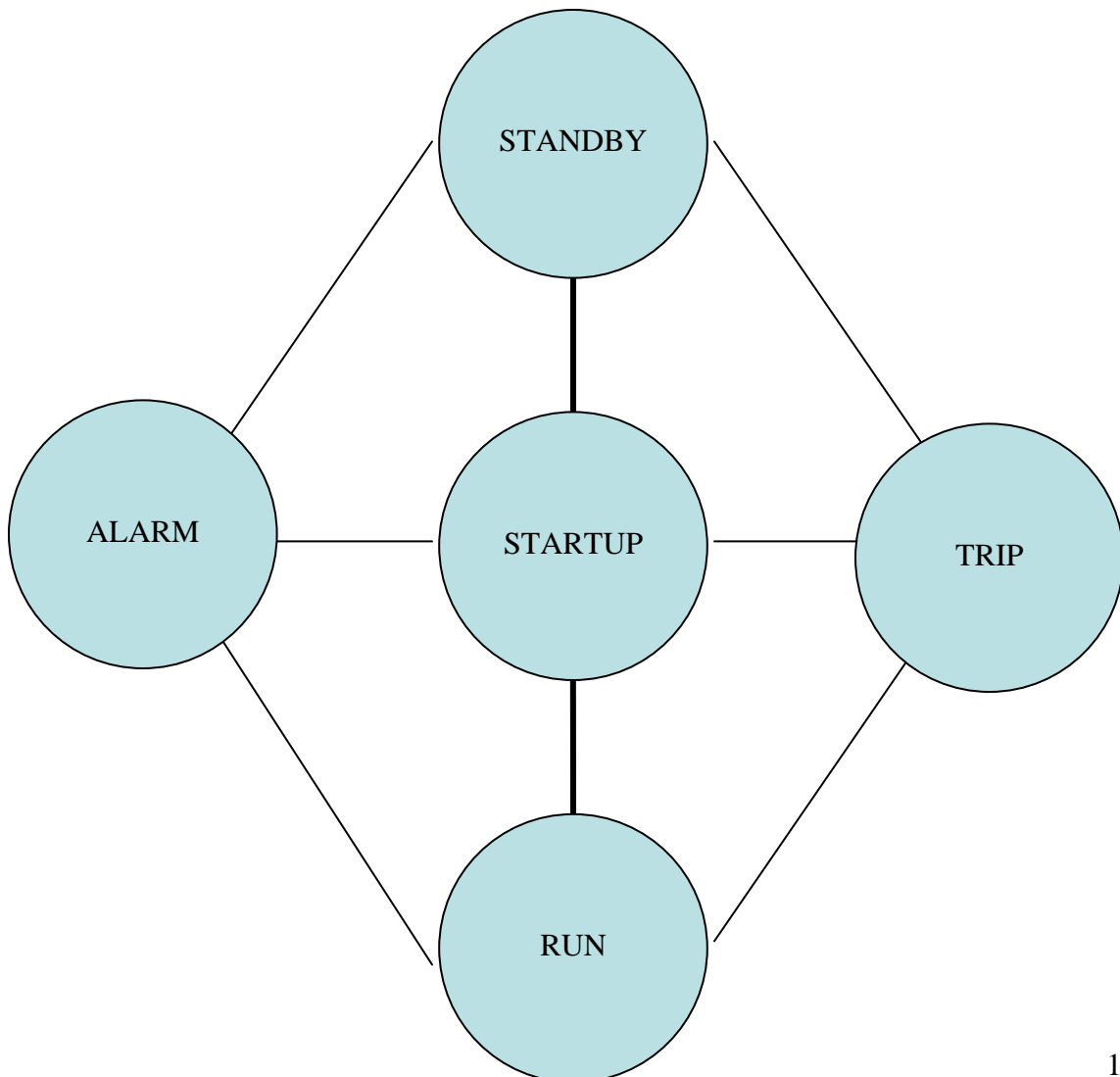

## 13. About

- Version 1.0 Unique version number
- Serial no. 48AC-B21F Unique serial number
- NINGI SERVICES Company
- [www.ningi.com](http://www.ningi.com) Web site
- 0800 000 400 24/7 Toll free telephone technical support
- 082 556 7682 Contact number (Tino)

## 14. Electrical specifications

	Min	Typical	Max	Unit
Control voltage	85		265	VAC
Power consumption		2	5	VA
Phase input voltage	0		250	VAC
Phase voltage sample rate		64000		S/Sec
Phase voltage accuracy			0.5	%
Relay contacts (2 x CO)	40		240	VAC
Relay contacts (2 x CO)	0.1		8	A
Earth leakage measurement sample rate		64000		S/Sec
Earth leakage measurement accuracy			0.5	%
Earth leakage measurement range	0.03		10.0	A
Input 1	0		250	VAC
Trip time instantaneous			25	mS
Trip time accuracy			0.1	%

# 15. Terms and conditions

## ***Product Agreement***

PTYTRADE384 (PTY) LTD reserves the right to make changes without further notice to any products herein.

The use of the EL1 indicates your understanding and acceptance of the following terms and conditions. This agreement shall supersede any verbal or prior verbal or written, statement or agreement to the contrary. If you do not understand or accept these terms, or your local regulations prohibit "after sale" product agreements or limited disclaimers, you must cease and desist using this product immediately.

This product is © Copyright 1998-2005 PTYTRADE384 (PTY) LTD, all rights reserved. International copyright laws, international treaties and all other applicable national or international laws protect this product. This product and documentation may not, in whole or in part, be copied, translated, or reduced to any electronic medium or machine readable form, without prior consent in writing, from PTYTRADE384 (PTY) LTD and according to all applicable laws.

The sole owners of this product PTYTRADE384 (PTY) LTD and NINGI SERVICES

### LIABILITY DISCLAIMER

PTYTRADE384 (PTY) LTD makes no warranty, representation or guarantee regarding the suitability of its products for any particular purpose, nor does PTYTRADE384 (PTY) LTD assume any liability arising out of the application or use of any product or circuit, and specifically disclaims any and all liability, including without limitation consequential or incidental damages. "Typical" parameters which may be provided in the data sheets and/or specifications can and do vary in different applications and actual performance may vary over time. All operating parameters, including "Typical" must be validated for each customer application by customer's technical experts. PTYTRADE384 (PTY) LTD does not convey any license under its patent rights nor the rights of others. PTYTRADE384 (PTY) LTD products are not designed, intended, or authorized for use as components in systems intended for surgical implant into the body, or other applications intended to support or sustain life, or for any other application in which the failure of the PTYTRADE384 (PTY) LTD product could create a situation where personal injury or death may occur. Should the customer use PTYTRADE384 (PTY) LTD products for any such unintended or unauthorized application, the customer shall indemnify and hold PTYTRADE384 (PTY) LTD and its officers, employees, subsidiaries, affiliates, and distributors harmless against all claims, costs, damages, and expenses, and attorney fees arising out of, directly or indirectly, any claim of personal injury or death associated with such unintended or unauthorized use, even if such claim alleges that PTYTRADE384 (PTY) LTD was negligent regarding the design or manufacture of the part. EL1 is a registered trademark of PTYTRADE384 (PTY) LTD. PTYTRADE384 (PTY) LTD does not assume liability for the use of this product beyond the original purchase price of the product.

### RESTRICTIONS

You may not use, copy or modify any documentation as expressly defined in this agreement. You may not attempt to unlock or bypass any authentication algorithm utilized by the product. You may not remove or modify any copyright notice or the method by which it may be invoked.

### OTHER RIGHTS AND RESTRICTIONS

All other rights and restrictions not specifically granted in this agreement are reserved by PTYTRADE384 (PTY) LTD.